

# 133 MHz Spread Spectrum Clock Synthesizer/Driver with Differential CPU Outputs

## Features

- Multiple output clocks at different frequencies
  - Four pairs of differential CPU outputs, up to 133 MHz
  - Ten synchronous PCI clocks, three free-running
  - Six 3V66 clocks
  - Two 48-MHz clocks
  - One reference clock at 14.318 MHz
  - One VCH clock
- Spread Spectrum clocking (down spread)
- Power-down features (PCI\_STOP#, PD#)
- Three Select inputs (Mode select & IC Frequency Select)
- OE and Test Mode support
- 56-pin SSOP package and 56-pin TSSOP package

## Benefits

- Motherboard clock generator
  - Support Multiple CPUs and a chipset
  - Support for PCI slots and chipset
  - Supports AGP and Hub Link
  - Supports USB host controller and graphic controller
  - Supports ISA slots and I/O chip
- Enables reduction of EMI and overall system cost
- Enables ACPI compliant designs
- Supports up to four CPU clock frequencies
- Enables ATE and “bed of nails” testing
- Widely available, standard package enables lower cost

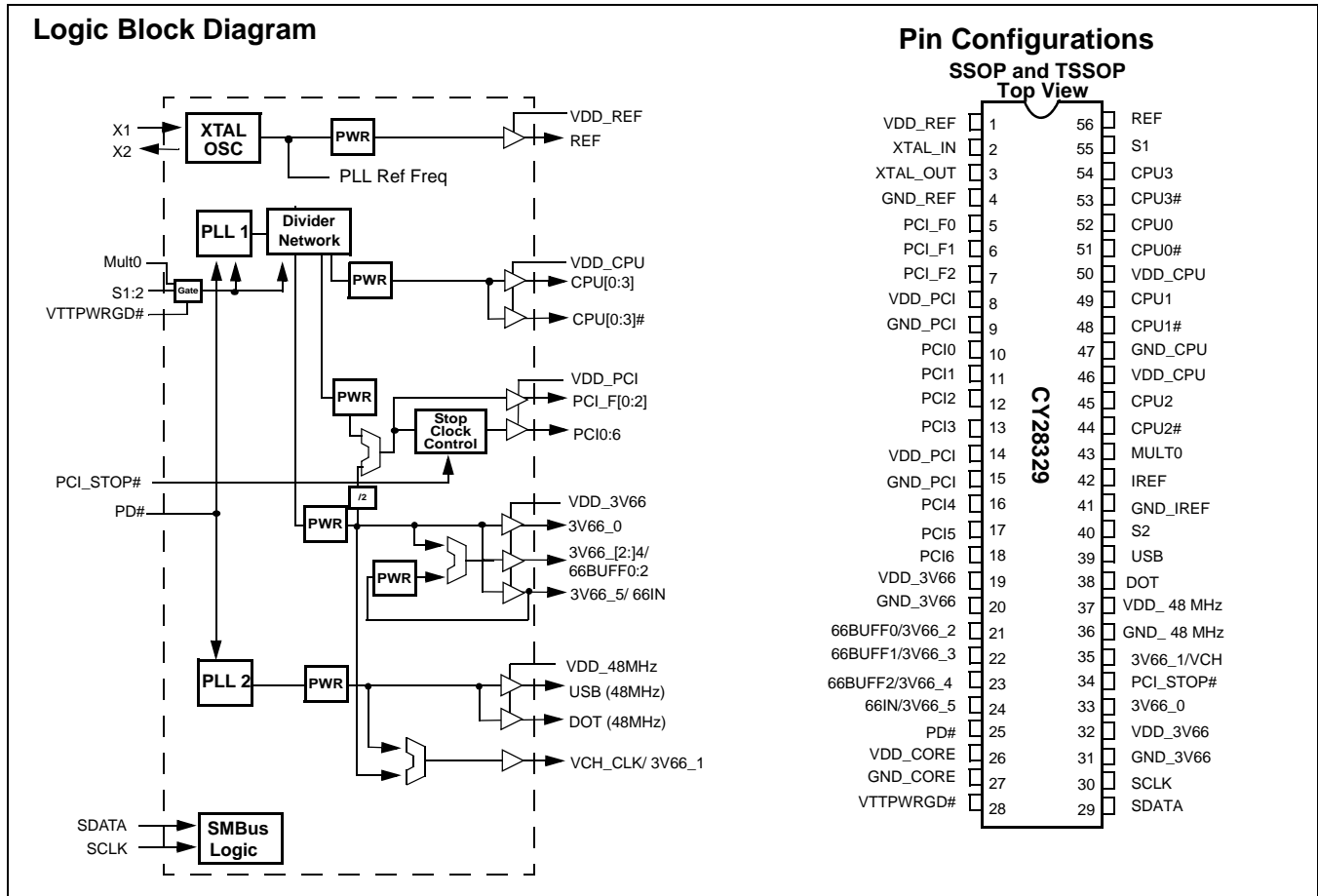

**Pin Description**

<b>Name</b>	<b>Pins</b>	<b>Description</b>
REF	56	<b>3.3V 14.318 MHz clock output</b>
XTAL_IN	2	<b>14.318 MHz crystal input</b>
XTAL_OUT	3	<b>14.318 MHz crystal input</b>
CPU, CPU [0:3]#	44, 45, 48, 49, 51, 52, 53, 54	<b>Differential CPU clock outputs</b>
3V66_0	33	<b>3.3V 66 MHz clock output</b>
3V66_1/VCH	35	<b>3.3V selectable through SMBus to be 66 MHz or 48 MHz</b>
66IN/3V66_5	24	<b>66 MHz input to buffered 66BUFF and PCI or 66 MHz clock from internal VCO</b>
66BUFF [0:2] /3V66 [2:4]	21, 22, 23	<b>66 MHz buffered outputs from 66Input or 66 MHz clocks from internal VCO</b>
PCI_F [0:2]	5, 6, 7,	<b>33 MHz clocks divided down from 66Input or divided down from 3V66</b>
PCI [0:6]	10, 11, 12, 13, 16, 17, 18	<b>PCI clock outputs divided down from 66Input or divided down from 3V66</b>
USB	39	<b>Fixed 48 MHz clock output</b>
DOT	38	<b>Fixed 48 MHz clock output</b>
S2	40	<b>Special 3.3V 3-level input for Mode selection</b>
S1	55	<b>3.3V LVTTTL inputs for CPU frequency selection</b>
IREF	42	<b>A precision resistor is attached to this pin which is connected to the internal current reference</b>
MULT0	43	<b>3.3V LVTTTL input for selecting the current multiplier for the CPU outputs</b>
PD#	25	<b>3.3V LVTTTL input for Power_Down# (active LOW). Do not add any decoupling capacitors. Use an external 1.0-K<math>\Omega</math> pull-up resistor.</b>
PCI_STOP#	34	<b>3.3V LVTTTL input for PCI_STOP# (active LOW)</b>
VTTTPWRGD#	28	<b>3.3V LVTTTL input is a level-sensitive strobe used to determine when S[1:2] and MULT0 inputs are valid and OK to be sampled (Active LOW). Once VTTTPWRGD# is sampled LOW, the status of this output will be ignored.</b>
SDATA	29	<b>SMBus-compatible SDATA</b>
SCLK	30	<b>SMBus-compatible Sclk</b>
VDD_REF, VDD_PCI, VDD_3V66, VDD_48 MHz, VDD_CPU	1, 8, 14, 19, 32, 37, 46, 50	<b>3.3V power supply for outputs</b>
VDD_CORE	26	<b>3.3V power supply for PLL</b>
GND_REF, GND_PCI, GND_3V66, GND_IREF, VDD_CPU	4, 9, 15, 20, 31, 36, 41, 47	<b>Ground for outputs</b>
GND_CORE	27	<b>Ground for PLL</b>

**Function Table<sup>[1]</sup>**

S2	S1	CPU (MHz)	3V66[0:1](MHz)	66BUFF[0:2]/3V66[2:4](MHz)	66IN/3V66_5 (MHz)	PCI_F/PCI (MHz)	REF0(MHz)	USB/DOT (MHz)	Notes
1	0	100 MHz	66 MHz	66IN	66-MHz Input	66IN/2	14.318 MHz	48 MHz	2, 3, 4
1	1	133 MHz	66 MHz	66IN	66-MHz Input	66IN/2	14.318 MHz	48 MHz	2, 3, 4
0	0	100 MHz	66 MHz	66 MHz	66-MHz Input	33 MHz	14.318 MHz	48 MHz	2, 3, 4
0	1	133 MHz	66 MHz	66 MHz	66-MHz Input	33 MHz	14.318 MHz	48 MHz	2, 3, 4
Mid	0	Hi-Z	Hi-Z	Hi-Z	Hi-Z	Hi-Z	Hi-Z	Hi-Z	5, 6
Mid	1	TCLK/2	TCLK/4	TCLK/4	TCLK/4	TCLK/8	TCLK	TCLK/2	1, 6

**Swing Select Functions**

Mult0	Board Target Trace/Term Z	Reference R, IREF = $V_{DD}/(3 \cdot R_r)$	Output Current	$V_{OH}$ @ Z,
0	50 ohm	$R_r = 221 \%$ , IREF = 5.00 mA	$I_{OH} = 4 \cdot I_{ref}$	1.0V @ 50
1	50 ohm	$R_r = 475 \%$ , IREF = 2.32 mA	$I_{OH} = 6 \cdot I_{ref}$	0.7V @ 50

**Clock Driver Impedances**

Buffer Name	$V_{DD}$ Range	Buffer Type	Impedance		
			Min. (Ohm)	Typ. (Ohm)	Max. (Ohm)
CPU, CPU#		Type X1		50	
REF	3.135–3.465	Type 3	20	40	60
PCI, 3V66, 66BUFF	3.135–3.465	Type 5	12	30	55
USB	3.135–3.465	Type 3A	12	30	55
DOT	3.135–3.465	Type 3B	12	30	55

**Clock Enable Configuration**

PD#	PCI_STOP#	CPU	CPU#	3V66	66BUFF	PCI_F	PCI	USB/DOT	VCOS/OSC
0	X	IREF*2	FLOAT	LOW	LOW	LOW	LOW	LOW	OFF
1	0	ON	ON	ON	ON	ON	OFF	ON	ON
1	1	ON	ON	ON	ON	ON	ON	ON	ON

**Notes:**

1. TCLK is a test clock driven in on the XTALIN input in test mode.
2. "Normal" mode of operation.
3. Range of reference frequency allowed is min. = 14.316 nominal = 14.31818 MHz, max. = 14.32 MHz.
4. Frequency accuracy of 48 MHz must be +167 PPM to match USB default.
5. Required for board level "bed of nails" testing.
6. Mid is defined a Voltage level between 1.0V and 1.8V for 3 level input functionality. Low is below 0.8V. High is above 2.0V.

### Serial Data Interface (SMBus)

To enhance the flexibility and function of the clock synthesizer, a two-signal SMBus interface is provided according to SMBus specification. Through the Serial Data Interface, various device functions such as individual clock output buffers, etc. can be individually enabled or disabled. CY28329 support both block read and block write operations.

The registers associated with the Serial Data Interface initializes to its default setting upon power-up, and therefore use of this interface is optional. Clock device register changes are normally made upon system initialization, if any are required. The interface can also be used during system operation for power management functions.

#### Data Protocol

The clock driver serial protocol accepts only Block Writes from the controller. The bytes must be accessed in sequential order from lowest to highest byte, (most significant bit first) with the ability to stop after any complete byte has been transferred. Indexed bytes are not allowed.

A Block write begins with a slave address and a WRITE condition. The R/W bit is used by the SMBus controller as a data direction bit. A zero indicates a WRITE condition to the clock device. The slave receiver address is 11010010 (D2h).

A command code of 0000 0000 (00h) and the byte count bytes are required for any transfer. After the command code, the core logic issues a byte count, which describes number of additional bytes required for the transfer, not including the command code and byte count bytes. For example, if the host has 20 data bytes to send, the first byte would be the number 20 (14h), followed by the 20 bytes of data. The byte count byte is required to be a minimum of 1 byte and a maximum of 32 bytes. It may not be 0. *Figure 1* shows an example of a block write.

A transfer is considered valid after the acknowledge bit corresponding to the byte count is read by the controller.

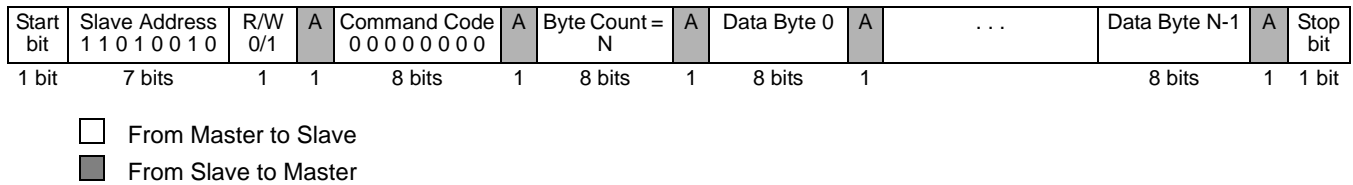

**Figure 1. An Example of a Block Write**

### Data Byte Configuration Map

**Data Byte 0: Control Register (0 = Enable, 1 = Disable)**

Bit	Affected Pin#	Name	Description	Type	Power On Default
Bit 7	5, 6, 7, 10, 11, 12, 13, 16, 17, 18, 33, 35	PCI [0:6] CPU[3:0] 3V66[1:0]	Spread Spectrum Enable 0 = Spread Off, 1 = Spread On	R/W	0
Bit 6	–	–	Reserved, set = 0	R	0
Bit 5	35	3V66_1/VCH	VCH Select 66 MHz/48 MHz 0 = 66 MHz, 1 = 48 MHz	R/W	0
Bit 4	–	–	Reserved	R	1
Bit 3	10, 11, 12, 13, 16, 17, 18	PCI [6:0]	PCI_STOP#, 0 = stopped, 1 = running (Does not affect PCI_F [2:0] pins)	R/W	1
Bit 2	40	S2	S2 Reflects the value of the S2 pin sampled on Power-up	R	HW
Bit 1	55	S1	S1 Reflects the value of the S1 pin sampled on Power-up	R	HW
Bit 0	–	–	Reserved	R	1

**Data Byte 1:**

Bit	Pin#	Name	Description	Type	Power On Default
Bit 7	–		CPU Mult0 Value	R	HW
Bit 6	53, 54	CPU3 CPU3#	CPU3 Output Enable 1 = Enabled; 0 = Disabled	R/W	1
Bit 5	–	–	Reserved, set = 0	R/W	0
Bit 4	–	–	Reserved, set = 0	R/W	0
Bit 3	–	–	Reserved, set = 0	R/W	0
Bit 2	44, 45	CPU2 CPU2#	CPU2 Output Enable 1 = Enabled; 0 = Disabled	R/W	1
Bit 1	48, 49	CPU1 CPU1#	CPU1 Output Enable 1 = Enabled; 0 = Disabled	R/W	1
Bit 0	51, 52	CPU0 CPU0#	CPU0 Output Enable 1 = Enabled; 0 = Disabled	R/W	1

**Data Byte 2:**

Bit	Pin#	Name	Pin Description	Type	Power On Default
Bit 7	–	–	Reserved, set = 0	R	0
Bit 6	18	PCI6	PCI6 Output Enable 1 = Enabled; 0 = Disabled	R/W	1
Bit 5	17	PCI5	PCI5 Output Enable 1 = Enabled; 0 = Disabled	R/W	1
Bit 4	16	PCI4	PCI4 Output Enable 1 = Enabled; 0 = Disabled	R/W	1
Bit 3	13	PCI3	PCI3 Output Enable 1 = Enabled; 0 = Disabled	R/W	1
Bit 2	12	PCI2	PCI2 Output Enable 1 = Enabled; 0 = Disabled	R/W	1
Bit 1	11	PCI1	PCI1 Output Enable 1 = Enabled; 0 = Disabled	R/W	1
Bit 0	10	PCI0	PCI0 Output Enable 1 = Enabled; 0 = Disabled	R/W	1

**Data Byte 3:**

Bit	Pin#	Name	Pin Description	Type	Power On Default
Bit 7	38	DOT	DOT 48 MHz Output Enable, 1 = enabled, 0 = disabled	R/W	1
Bit 6	39	USB	USB 48 MHz Output Enable, 1 = enabled, 0 = disabled	R/W	1
Bit 5	7	PCI_F2	Allow control of PCI_F2 with assertion of PCI_STOP# 0 = Free running; 1 = Stopped with PCI_STOP#	R/W	0
Bit 4	6	PCI_F1	Allow control of PCI_F1 with assertion of PCI_STOP# 0 = Free running; 1 = Stopped with PCI_STOP#	R/W	0
Bit 3	5	PCI_F0	Allow control of PCI_F0 with assertion of PCI_STOP# 0 = Free running; 1 = Stopped with PCI_STOP#	R/W	0
Bit 2	7	PCI_F2	PCI_F2 Output Enable, 1 = enabled, 0 = disabled	R/W	1
Bit 1	6	PCI_F1	PCI_F1 Output Enable, 1 = enabled, 0 = disabled	R/W	1
Bit 0	5	PCI_F0	PCI_F0 Output Enable, 1 = enabled, 0 = disabled	R/W	1

**Data Byte 4:**

Bit	Pin#	Name	Pin Description	Type	Power On Default
Bit 7	–		Reserved, set = 0	R	0
Bit 6	–		Reserved, set = 0	R	0
Bit 5	33	3V66_0	3V66_0 Output Enable 1 = Enabled; 0 = Disabled	R/W	1
Bit 4	35	3V66_1/VCH	3V66_1/VCH Output Enable 1 = Enabled; 0 = Disabled	R/W	1
Bit 3	24	66IN/3V66_5	3V66_5 Output Enable 1 = Enable; 0 = Disable <b>Note:</b> This bit should be used when pin 24 is configured as 3V66_5 output. do not clear this bit when pin 24 is configured as 66IN input.	R/W	1
Bit 2	23	66BUFF2	66-MHz Buffered 2 Output Enable 1 = Enabled; 0 = Disabled	R/W	1
Bit 1	22	66BUFF1	66-MHz Buffered 1 Output Enable 1 = Enabled; 0 = Disabled	R/W	1
Bit 0	21	66BUFF0	66-MHz Buffered 0 Output Enable 1 = Enabled; 0 = Disabled	R/W	1

**Data Byte 5:**

Bit	Pin#	Name	Pin Description	Type	Power On Default
Bit 7			Reserved, set = 0	R	0
Bit 6			Reserved, set = 0	R	0
Bit 5	21,22,23	66BUFF [2:0]	Tpd 66IN to 66BUFF propagation delay control	R/W	0
Bit 4				R/W	0
Bit 3	38	DOT	DOT edge rate control	R/W	0
Bit 2				R/W	0
Bit 1	39	USB	USB edge rate control	R/W	0
Bit 0				R/W	0

**Byte 6: Vendor ID**

Bit	Description	Type	Power On Default
Bit 7	Revision Code Bit 3	R	0
Bit 6	Revision Code Bit 2	R	0
Bit 5	Revision Code Bit 1	R	0
Bit 4	Revision Code Bit 0	R	0
Bit 3	Vendor ID Bit 3	R	1
Bit 2	Vendor ID Bit 2	R	0
Bit 1	Vendor ID Bit 1	R	0
Bit 0	Vendor ID Bit 0	R	0

**Absolute Maximum Conditions**

(Above which the useful life may be impaired. For user guidelines, not tested.)

Supply Voltage ..... -0.5 to +7.0V  
 Input Voltage ..... -0.5V to  $V_{DD} + 0.5$

Storage Temperature (Non-Condensing) .... -65°C to +150°C  
 Max. Soldering Temperature (10 sec.) ..... +260°C  
 Junction Temperature ..... +150°C  
 Package Power Dissipation ..... 1W  
 Static Discharge Voltage .....  
 (per MIL-STD-883, Method 3015) ..... > 2000V

**Operating Conditions** over which electrical parameters are guaranteed<sup>[7]</sup>

Parameter	Description	Min.	Max.	Unit
$V_{DD\_REF}$ , $V_{DD\_PCI}$ , $V_{DD\_CORE}$ , $V_{DD\_3V66}$ , $V_{DD\_48\ MHz}$ , $V_{DD\_CPU}$ ,	3.3V Supply Voltages	3.135	3.465	V
$T_A$	Operating Temperature, Ambient	0	70	°C
$C_{in}$	Input Pin Capacitance		5	pF
$C_{XTAL}$	XTAL Pin Capacitance		22.5	pF
$C_L$	Max. Capacitive Load on USBCLK, REF PCICLK, 3V66		20 30	pF
$f_{(REF)}$	Reference Frequency, Oscillator Nominal Value	14.318	14.318	MHz

**DC Electrical Specifications** Over the Operating Range

Parameter	Description	Test Conditions		Min.	Max.	Unit
$V_{IH}$	High-level Input Voltage	Except Crystal Pads. Threshold voltage for crystal pads = $V_{DD}/2$		2.0		V
$V_{IL}$	Low-level Input Voltage	Except Crystal Pads			0.8	V
$V_{OH}$	High-level Output Voltage	USB, REF, 3V66	$I_{OH} = -1\ mA$	2.4		V
		PCI	$I_{OH} = -1\ mA$	2.4		V
$V_{OL}$	Low-level Output Voltage	USB, REF, 3V66	$I_{OL} = 1\ mA$		0.4	V
		PCI	$I_{OL} = 1\ mA$		0.55	V
$I_{IH}$	Input High Current	$0 \leq V_{IN} \leq V_{DD}$		-5	5	mA
$I_{IL}$	Input Low Current	$0 \leq V_{IN} \leq V_{DD}$		-5	5	mA
$I_{OH}$	High-level Output Current	CPU For $I_{OH} = 6 \cdot I_{REF}$ Configuration	Type X1, $V_{OH} = 0.65V$	12.9		mA
			Type X1, $V_{OH} = 0.74V$		14.9	
		REF, DOT, USB	Type 3, $V_{OH} = 1.00V$	-29		
			Type 3, $V_{OH} = 3.135V$		-23	
		3V66, DOT, PCI	Type 5, $V_{OH} = 1.00V$	-33		
			Type 5, $V_{OH} = 3.135V$		-33	
$I_{OL}$	Low-level Output Current	REF, DOT, USB	Type 3, $V_{OL} = 1.95V$	29		mA
			Type 3, $V_{OL} = 0.4V$		27	
		3V66, PCI	Type 5, $V_{OL} = 1.95\ V$	30		
			Type 5, $V_{OL} = 0.4V$		38	
$I_{OZ}$	Output Leakage Current	Three-state			10	mA
$I_{DD3}$	3.3V Power Supply Current	$V_{DD\_CORE}/V_{DD3.3} = 3.465V$ , $F_{CPU} = 133\ MHz$			360	mA
$I_{DDPD3}$	3.3V Shutdown Current	$V_{DD\_CORE}/V_{DD3.3} = 3.465V$ and @ $I_{REF} = 2.32\ mA$			25	mA
$I_{DDPD3}$	3.3V Shutdown Current	$V_{DD\_CORE}/V_{DD3.3} = 3.465V$ and @ $I_{REF} = 5.0\ mA$			45	mA

**Note:**

7. Multiple Supplies: the voltage on any input or I/O pin cannot exceed the power pin during power-up. Power supply sequencing is NOT required.

**Switching Characteristics** Over the Operating Range<sup>[8]</sup>

Parameter	Output	Description	Test Conditions	Min.	Max.	Unit
t <sub>1</sub>	All	Output Duty Cycle <sup>[9]</sup>	Measured at 1.5V	45	55	%
t <sub>2</sub>	CPU	Rise Time	Measured differential waveform from -0.35V to +0.35V	175	700	ns
t <sub>2</sub>	USB, REF, DOT	Rising Edge Rate	Between 0.4V and 2.4V	0.5	2.0	ns
t <sub>2</sub>	PCI, 3V66	Rising Edge Rate	Between 0.4V and 2.4V	1.0	4.0	V/ns
t <sub>3</sub>	CPU	Fall Time	Measured differential waveform from -0.35V to +0.35V	175	700	ps
t <sub>3</sub>	USB, REF, DOT	Falling Edge Rate	Between 2.4V and 0.4V	0.5	2.0	ns
t <sub>3</sub>	PCI, 3V66	Falling Edge Rate	Between 2.4V and 0.4V	1.0	4.0	V/ns
t <sub>4</sub>	CPU	CPU-CPU Skew	Measured at Crossover		150	ps
t <sub>5</sub>	3V66 [0:1]	3V66-3V66 Skew	Measured at 1.5V		500	ps
t <sub>5</sub>	66BUFF[0:2]	66BUFF-66BUFF Skew	Measured at 1.5V		175	ps
t <sub>6</sub>	PCI	PCI-PCI Skew	Measured at 1.5V		500	ps
t <sub>7</sub>	3V66, PCI	3V66-PCI Clock Skew	3V66 leads. Measured at 1.5V	1.5	3.5	ns
t <sub>8</sub>	CPU	Cycle-Cycle Clock Jitter	Measured at Crossover t <sub>8</sub> = t <sub>8A</sub> - t <sub>8B</sub> With all outputs running		150	ps
t <sub>9</sub>	3V66	Cycle-Cycle Clock Jitter	Measured at 1.5V t <sub>9</sub> = t <sub>9A</sub> - t <sub>9B</sub>		250	ps
t <sub>9</sub>	USB, DOT	Cycle-Cycle Clock Jitter	Measured at 1.5V t <sub>9</sub> = t <sub>9A</sub> - t <sub>9B</sub>		350	ps
t <sub>9</sub>	PCI	Cycle-Cycle Clock Jitter	Measured at 1.5V t <sub>9</sub> = t <sub>9A</sub> - t <sub>9B</sub>		500	ps
t <sub>9</sub>	REF	Cycle-Cycle Clock Jitter	Measured at 1.5V t <sub>9</sub> = t <sub>9A</sub> - t <sub>9B</sub>		1000	ps
t <sub>10</sub>	ALL	POR timing	Measured at 1.5V <sup>[10, 11]</sup>	1.0	4.0	ms
	CPU	Rise/Fall Matching	Measured with test loads <sup>[12, 13]</sup>		235	mV
V <sub>oh</sub>	CPU	High-level Output Voltage including overshoot	Measured with test loads <sup>[13]</sup>	0.92	1.45	V
V <sub>ol</sub>	CPU	Low-level Output Voltage including undershoot	Measured with test loads <sup>[13]</sup>	-0.2	0.35	V
V <sub>crossover</sub>	CPU	Crossover Voltage	Measured with test loads <sup>[13]</sup>	0.250	0.550	V

**Notes:**

8. All parameters specified with loaded outputs.
9. Duty cycle is measured at 1.5V when V<sub>DD</sub> = 3.3V. When V<sub>DD</sub> = 2.5V, duty cycle is measured at 1.25V.
10. POR starts when V<sub>DD</sub> reaches 1.5V.
11. All PULL-UPS must ramp at the same rate as V<sub>DD</sub>.
12. Determined as a fraction of 2\*(Trp - Trn)/(Trp + Trn) Where Trp is a rising edge and Trn is an intersecting falling edge.
13. The test load is R<sub>s</sub> = 33.2Ω, R<sub>p</sub> = 49.9Ω in test circuit.

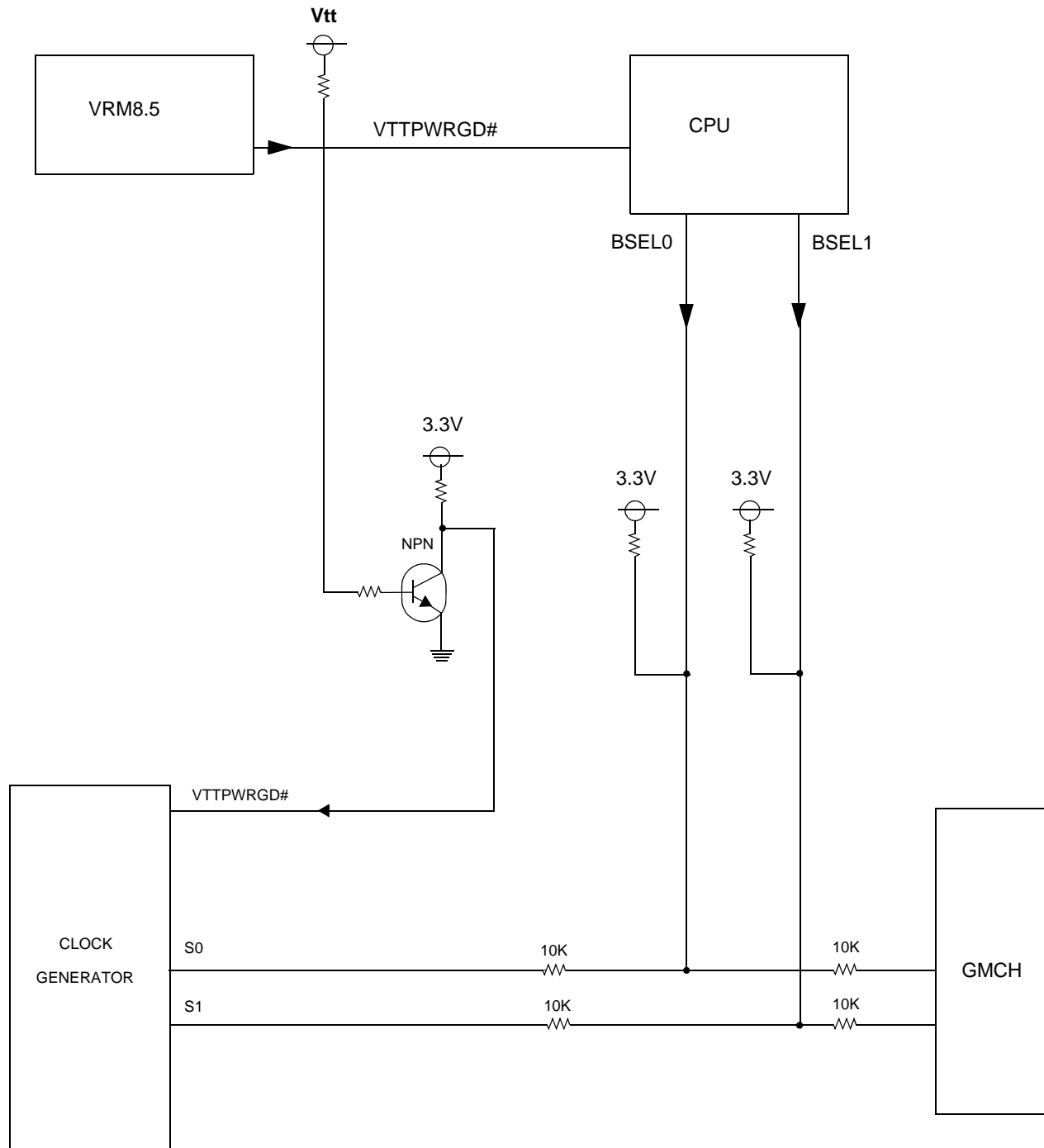
**Definition and Application of VTPWRGD# Signal**

## Switching Waveforms

### Duty Cycle Timing (Single-Ended Output)

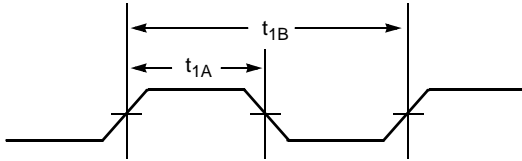

### Duty Cycle Timing (CPU Differential Output)

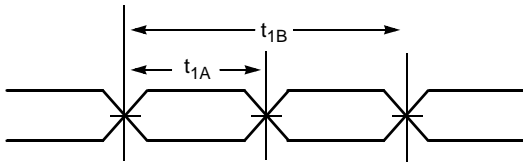

### All Outputs Rise/Fall Time

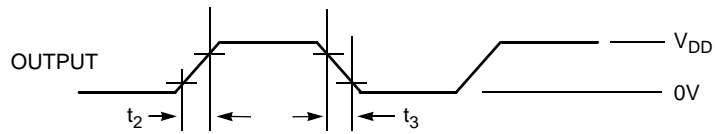

### CPU-CPU Clock Skew

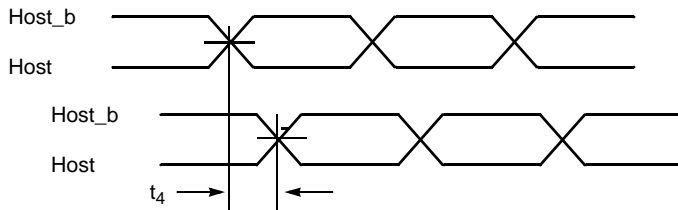

### 3V66-3V66 Clock Skew

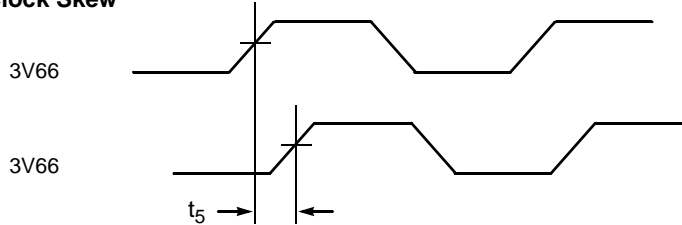

### PCI-PCI Clock Skew

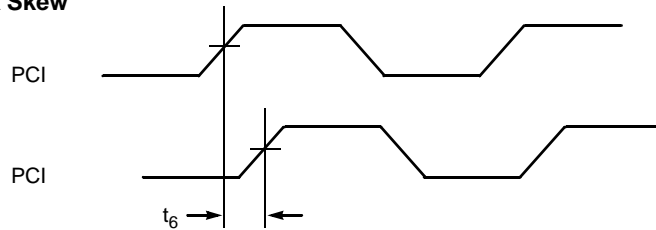

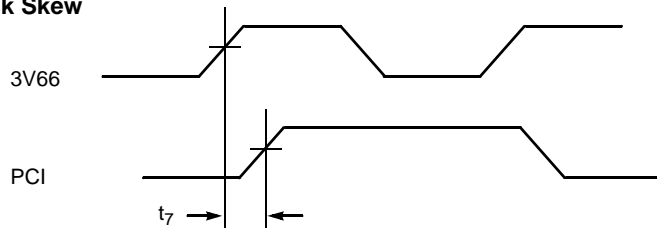
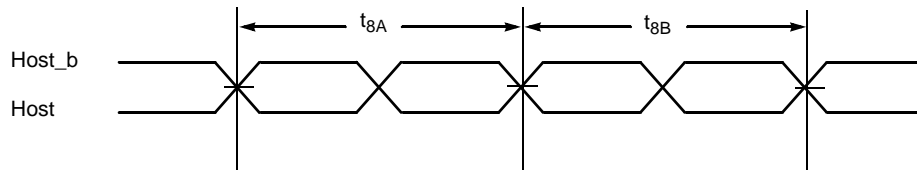
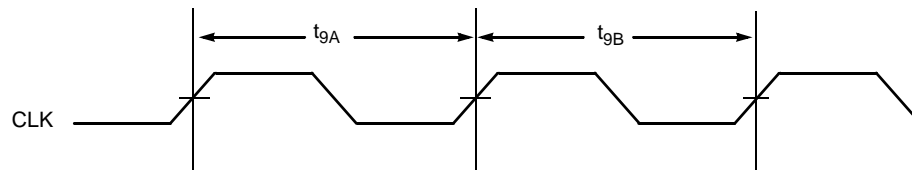
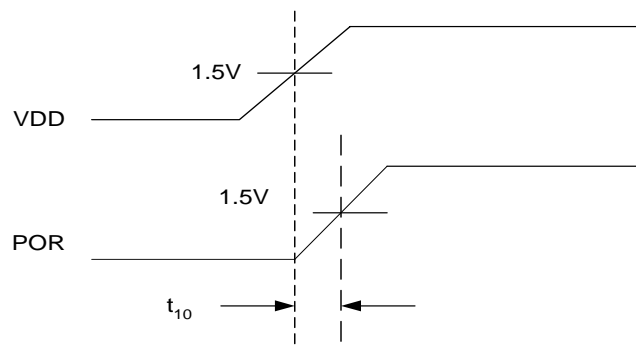
**Switching Waveforms (continued)**
**3V66-PCI Clock Skew**

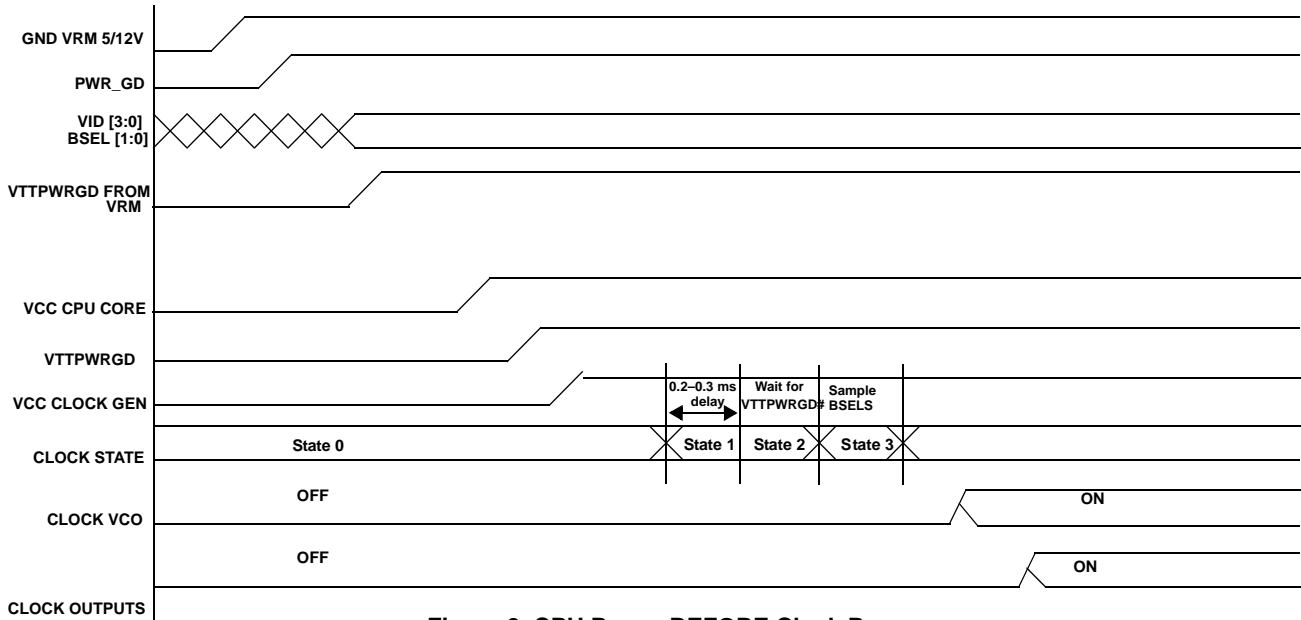
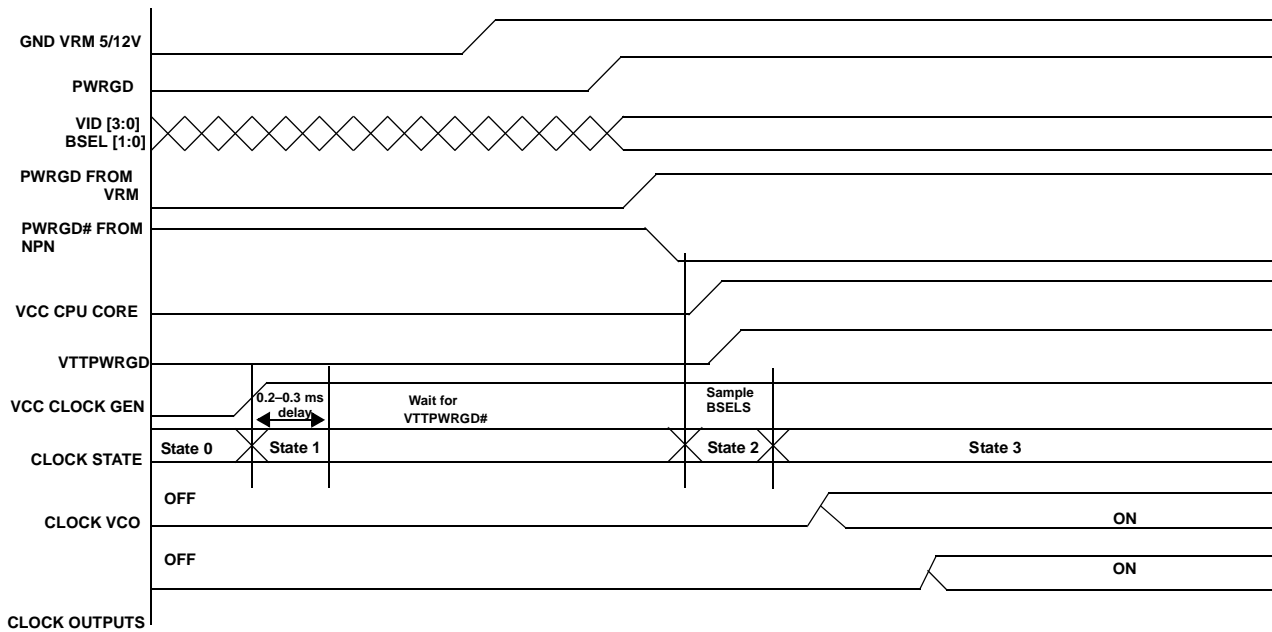
**CPU Clock Cycle-Cycle Jitter**

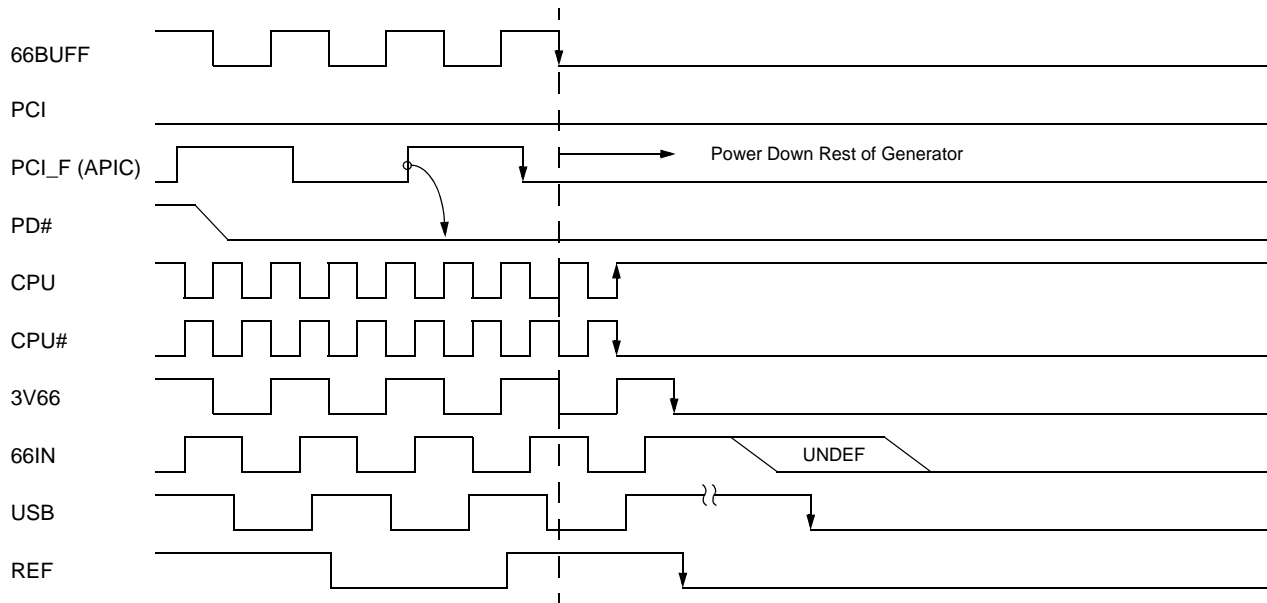
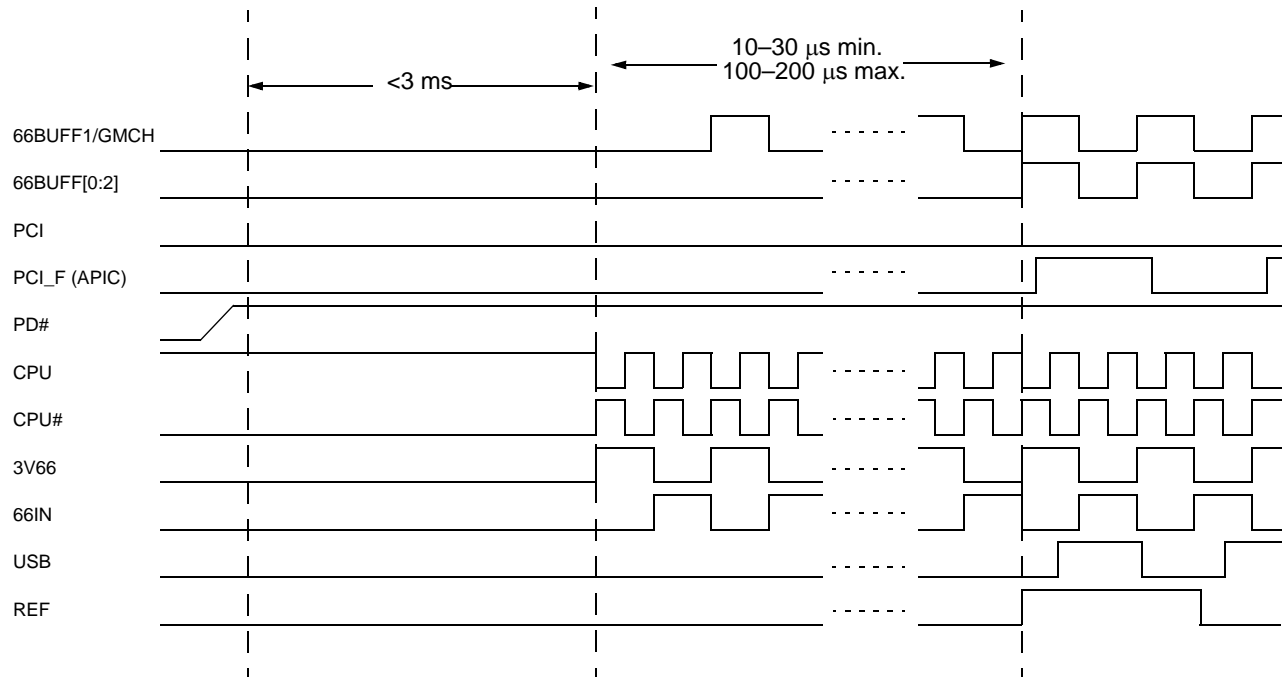
**Cycle-Cycle Clock Jitter**

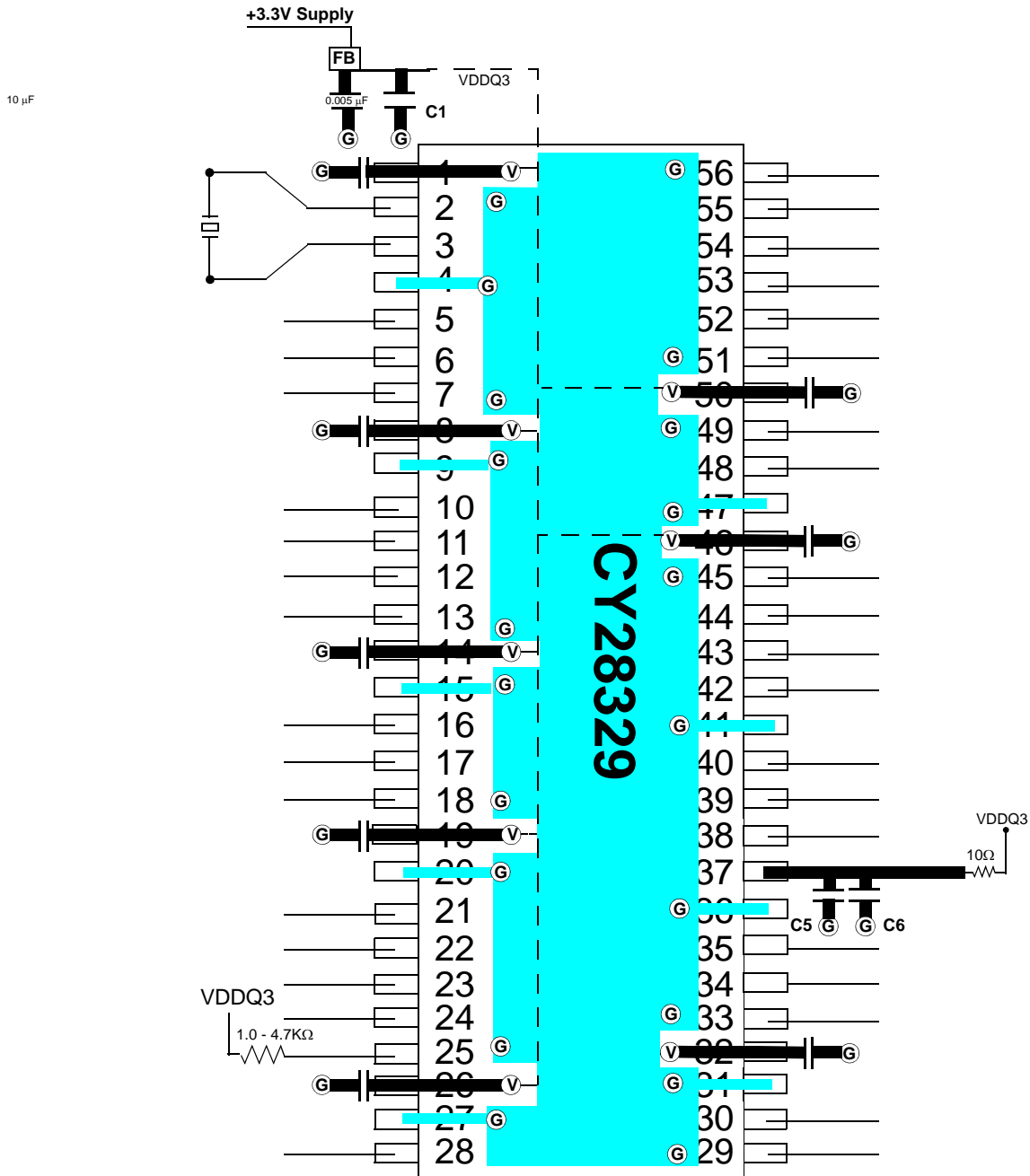
**VDD and POR Timing**

**VTPWRGD# Timing Diagrams**

**Figure 2. CPU Power BEFORE Clock Power**

**Figure 3. CPU Power AFTER Clock Power**

**PD# Assertion**

**PD# Deassertion**

**Layout Example**

FB = Dale ILB1206 - 300 or 2TDKACB2012L-120 or 2 Murata BLM21B601S

Ceramic Caps C1 = 10-22  $\mu\text{F}$  C2 = 0.005  $\mu\text{F}$  C5 = 0.1  $\mu\text{F}$  C6 = 10  $\mu\text{F}$

ⓐ = VIA to GND plane layer Ⓥ = VIA to respective supply plane layer

Note: Each supply plane or strip should have a ferrite bead and capacitors

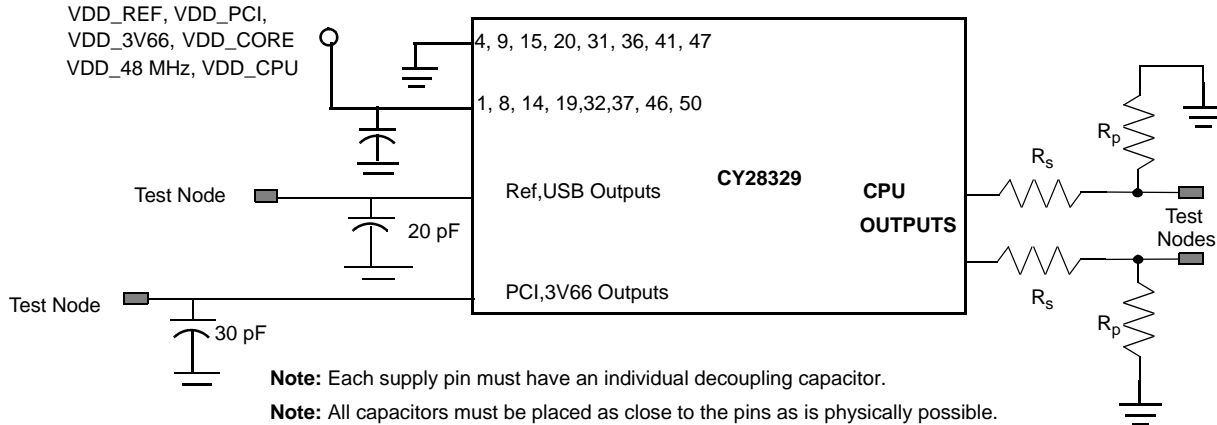
**Test Circuit**

**Ordering Information**

Ordering Code	Package Type	Operating Range
<b>Standard</b>		
CY28329PVC	56-Pin Small Shrunk Outline Package (SSOP)	Commercial
CY28329PVCT	56-Pin Small Shrunk Outline Package (SSOP) - Tape and Reel	Commercial
CY28329ZC	56-Pin Thin Small Shrunk Outline Package (TSSOP)	Commercial
CY28329ZCT	56-Pin Thin Small Shrunk Outline Package (TSSOP) - Tape and Reel	Commercial
<b>Lead-free</b>		
CY28329OXC	56-Pin Small Shrunk Outline Package (SSOP)	Commercial
CY28329OXCT	56-Pin Small Shrunk Outline Package (SSOP) - Tape and Reel	Commercial
CY28329ZXC	56-Pin Thin Small Shrunk Outline Package (TSSOP)	Commercial
CY28329ZXCT	56-Pin Thin Small Shrunk Outline Package (TSSOP)	Commercial

Package Drawing and Dimensions

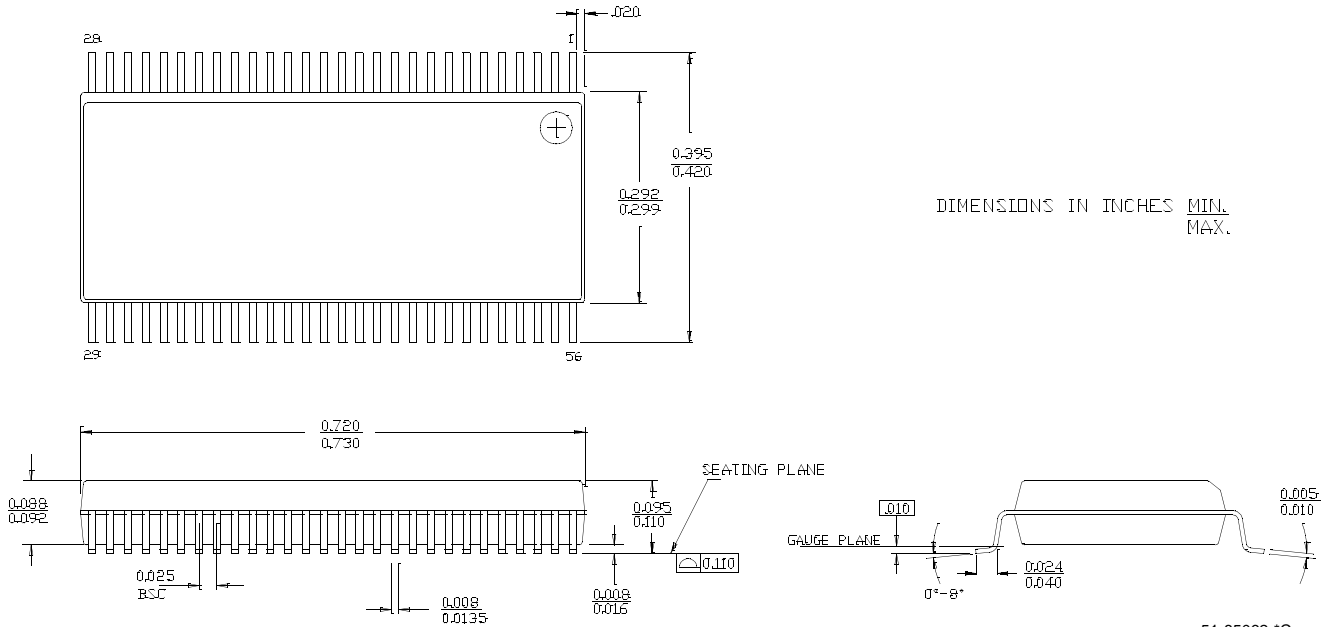
56-Lead Shrunk Small Outline Package O56



56-Lead Thin Shrunk Small Outline Package, Type II (6 mm x 12 mm) Z56

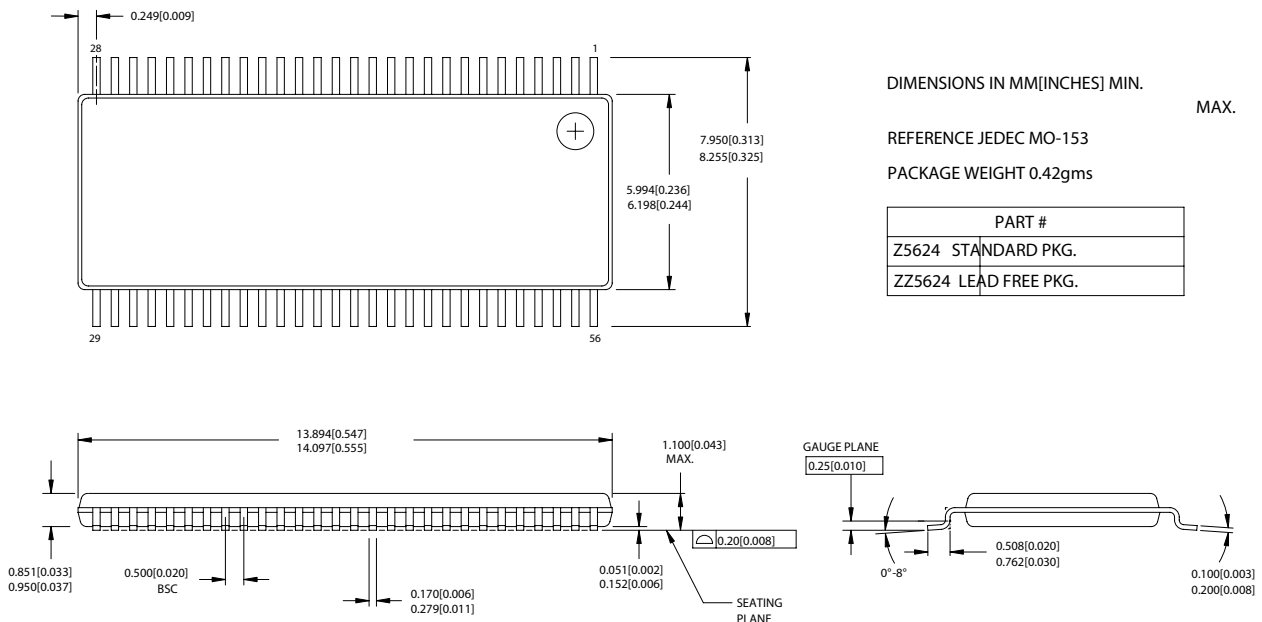

While SLI has reviewed all information herein for accuracy and reliability, Spectra Linear Inc. assumes no responsibility for the use of any circuitry or for the infringement of any patents or other rights of third parties which would result from each use. This product is intended for use in normal commercial applications and is not warranted nor is it intended for use in life support, critical medical instruments, or any other application requiring extended temperature range, high reliability, or any other extraordinary environmental requirements unless pursuant to additional processing by Spectra Linear Inc., and expressed written agreement by Spectra Linear Inc. Spectra Linear Inc. reserves the right to change any circuitry or specification without notice.